

ANNEX 1a

PERMITTED BITS FOR THE DRESSAGE TEST

Captions to plate showing permitted bits

Various bridoon bits

1. Ordinary bridoon bit
2. Bridoon bit with two joints
3. Egg-butt bridoon bit
4. Bridoon bit with cheeks or drop + cheek bridoon

Various types of curb bits

5. Half moon curb bit
- 6+7. Curb bit with straight cheeks and port
8. Curb bit with port and sliding mouthpiece (Weymouth)
9. Variation of bits No 6+7
10. Curb bit with S-curved cheeks
11. Curb chain
12. Lip strap
13. Leather cover curb chain
14. Rubber cover for curb chain

Drawings permitted bits

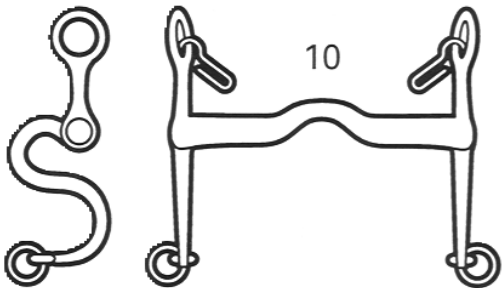
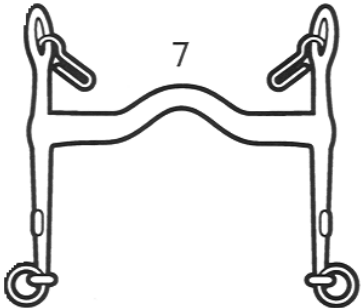
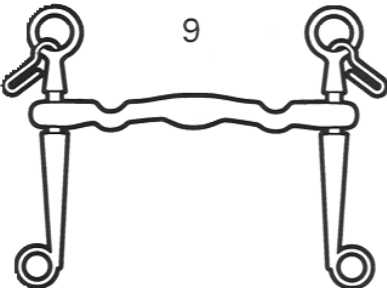
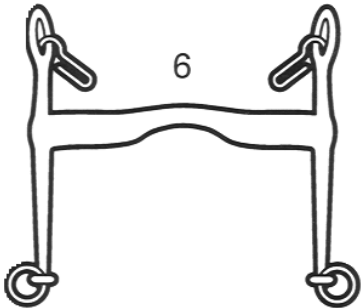
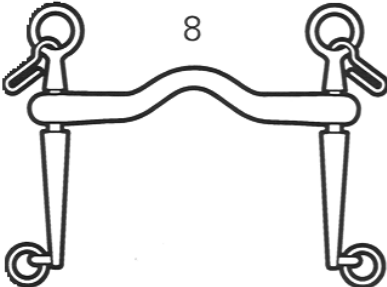
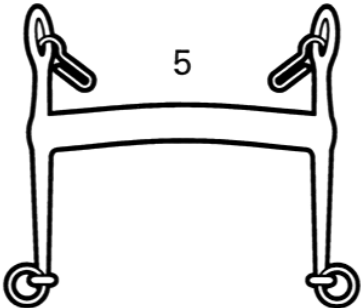
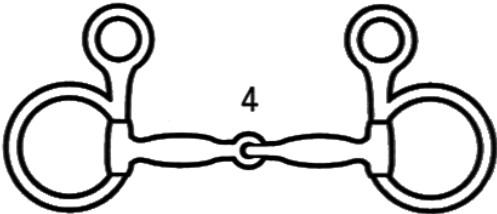
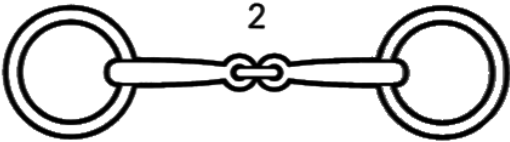
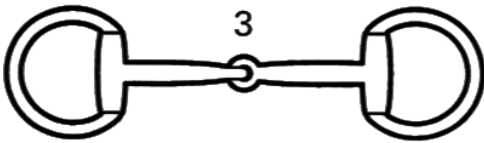
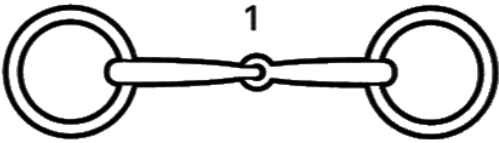

11



13



12

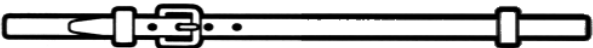

14



Note: all bridoon bits shown on the plate of permitted bits in both the "Rules for Eventing" and the "Rules for Dressage Events" are permitted for the Dressage Test of Eventing either as a snaffle or as part of a double bridle. A double bridle should always consist of a broken (simple or double) and a straight bit. Bits can be made out of plastic or metal.

Any of the rings or cheeks shown on this plate are permitted with any of the bits.

An ordinary snaffle is a plain snaffle with a straight bar or joint in the centre. If a snaffle has two joints, all parts must be rounded and smooth.

In addition, the following types of snaffle are permitted:

1. Ordinary snaffle with double-jointed mouthpiece
2. Ordinary snaffle with jointed mouthpiece
3. Racing snaffle - "D Ring"
4. Egg-butt snaffle:
 - a) with cheeks
 - b) without cheeks
5. Other type of snaffle with cheeks
6. Snaffle with upper cheeks only
7. Rubber, leather, rigid plastic or **steel** snaffle jointed or unjointed
8. Hanging cheek snaffle
9. Ordinary snaffle with double-jointed mouthpiece with lozenge
10. Ordinary snaffle with double-jointed mouth piece (French link)
11. Unjointed wavy rigid plastic or rubber snaffle (not steel):
 - a) with cheeks
 - b) without cheeks.
12. Ordinary snaffle with rotating mouthpiece
13. Snaffle with rotating middle piece

Drawings - permitted snaffles

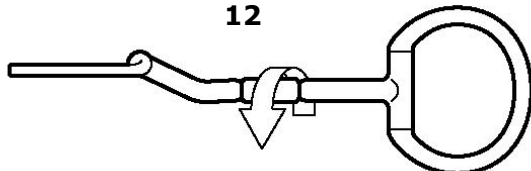
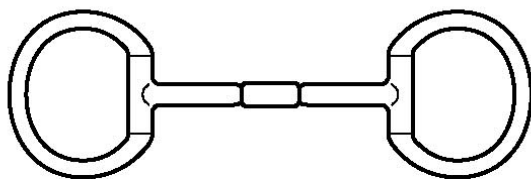
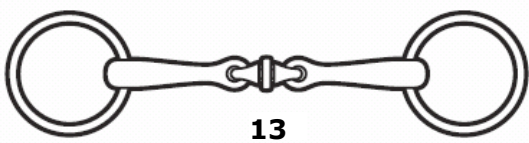
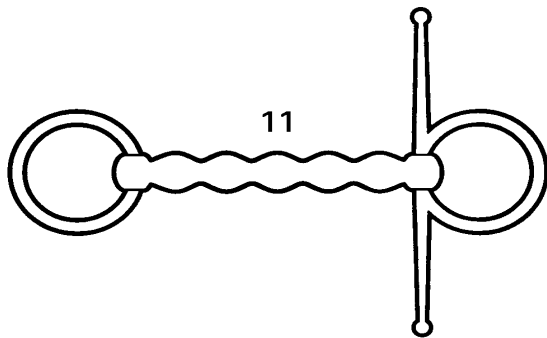
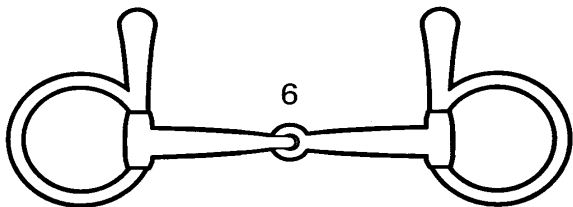
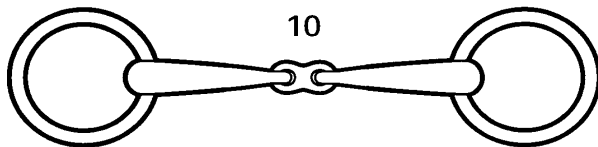
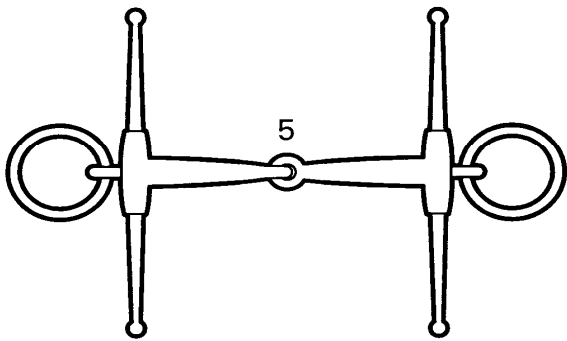
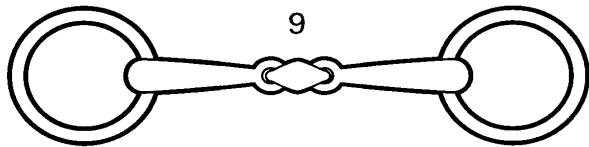
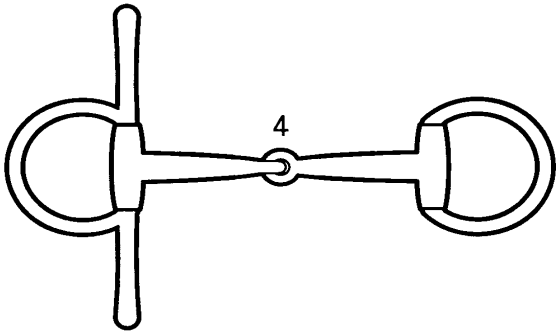
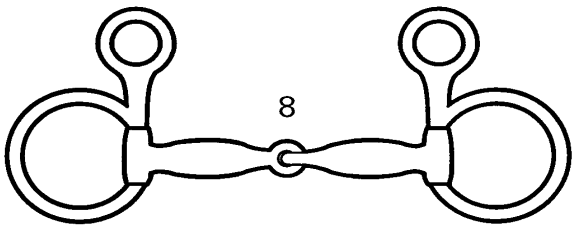
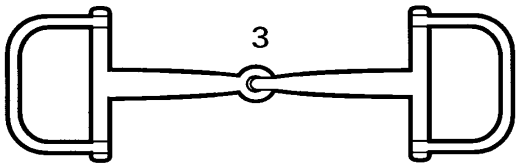
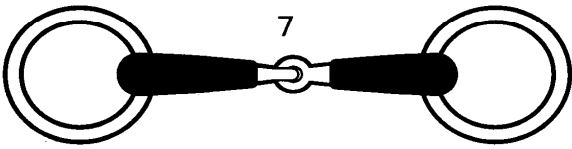
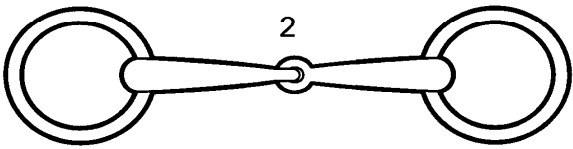
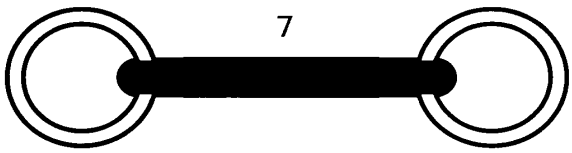
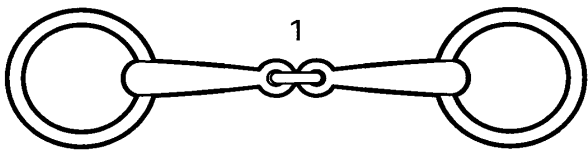

ANNEX 1b

PERMITTED NOSEBANDS FOR THE DRESSAGE TEST

1) Cavesson

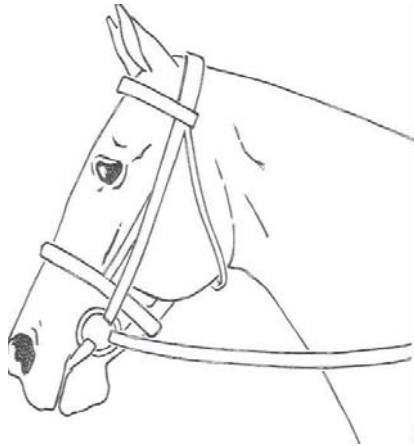

2) Crossed noseband

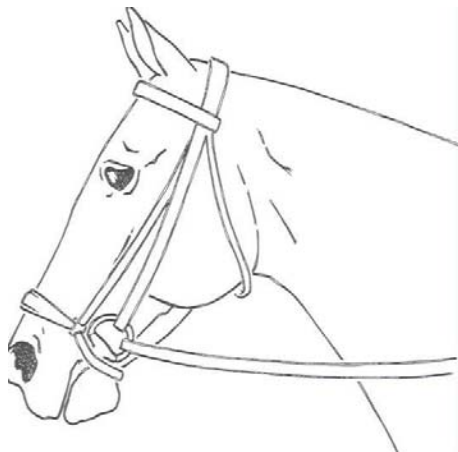
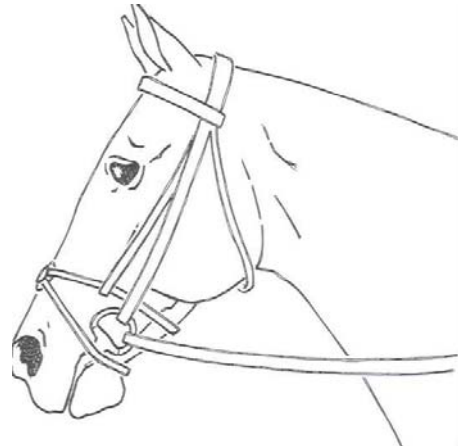

3) Dropped noseband

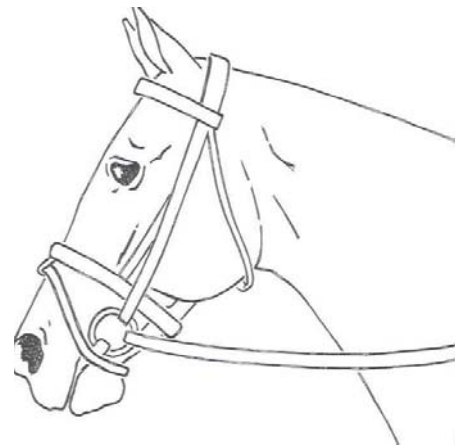

4) Flash noseband

2, 3 and 4 are not permitted when a double bridle is used

ANNEX 2

DRESSAGE TESTS FOR EVENTING

ONE Star Events (1*) CH/CCI/CIC	2009 A 1* test	approx 4 min	Annex 2.1
	2009 B 1* test	approx 5 min	Annex 2.2
TWO Star (2*)Events CH/CCI/CIC	2009 A 2* test	approx 5 min	Annex 2.3
	2009 B 2* test	approx 5 min	Annex 2.4
THREE Star (3*) Events CH/CCI/CIC	2009 A 3* test	approx 5 min	Annex 2.5
	2009 B 3* test	approx 5 min	Annex 2.6
FOUR Star (4*) Events CH/CCI	2009 A 4* test	approx 5 ¼ min	Annex 2.7
	2009 B 4* test	approx 5 ¼ min	Annex 2.8

Tests of each star level are used for CCIs or CICs.

Within the limits shown in Annex 4, Organising Committees are free to select the specific test to be used.

At Games, Championships and Cup Finals the dressage test to be used will be decided by the FEI.

- A Dressage tests would apply for all championships all levels in uneven years.
- B Dressage tests would apply for all championships of all star levels in even years

**ANNEX 3a– Table of CCI CROSS-COUNTRY OBSTACLE HEIGHTS & SPREADS /
TABLE OF SPEEDS, TIMES, DISTANCES & MAXIMUM JUMPING EFFORTS**

CCI CROSS COUNTRY	Four Star (4*)	Three Star (3*)	Two Star (2*)	One Star (1*)
Fixed	1.20 m	1.20 m	1.15 m	1.10 m
Brush	1.45 m	1.40 m	1.35 m	1.30 m
Max Spreads				
Highest Point	2.00 m	1.80 m	1.60 m	1.40 m
Base	3.00 m	2.70 m	2.40 m	2.10 m
Without height	4.00 m	3.60 m	3.20 m	2.80 m
Max Drops	2.00 m	2.00 m	1.80 m	1.60 m

ANNEX 3b – CCI / CIC Table of Speeds, times, distances & maximum Jumping Efforts

CCI CROSS COUNTRY	Four Star (4*)	Three Star (3*)	Two Star (2*)	One Star (1*)
Distance	6270-6840 m	5700-6270 m	4400–5500 m	4160-4680 m
Speed	570 mpm	570 mpm	550 mpm	520 mpm
Time	11–12 min	10-11 min	8-10 min	8-9 min
Jump. Efforts	Max 42-45	Max 40	Max 37	Max 32
Alternative				
Distance	5700-6270 m	5130-5700 m	4400-4950 m	3640-4160 m
Time	10-11 min	9-10 min	8-9 min	7-8 min
Jump. Efforts	Max 42-43	Max 38	Max 35	Max 30

CIC CROSS-COUNTRY	Three Star (3*)	Two Star (2*)	One Star (1*)
Distance	3200-4000 m	2800-3600 m	2400-3200 m
Speed	570 mpm	550 mpm	520 mpm
Time	Approx. 5-6.7 min	Approx. 5-6.5 min	Approx. 4.5-6 min
Jump. Efforts	Max-40	Max 36	Max 32

As a guideline, for CICs, the ratio of efforts is max. 1 effort per every commenced 110 metres (to be gradually enforced until 2010).

ANNEX 4 – Table of JUMPING OBSTACLE HEIGHTS & SPREADS / DISTANCES, SPEEDS & MAXIMUM JUMPING EFFORTS

JUMPING Championships, CCIs & CICs	Four Star (4*)	Three Star (3*)	Two Star (2*)	One Star (1*)
OBSTACLES				
Heights:	1.25 m	1.25 m	1.20 m	1.15 m
Overall Spreads:				
Oxers	1.45 m	1.45 m	1.40 m	1.35 m
Triple Bar	1.65 m	1.65 m	1.60 m	1.55 m
Distance	Max 600 m	Max 600 m	Max 600 m	Max 600 m
Speed	375 mpm Ω	375 mpm Ω	350 mpm Ω	350 mpm Ω
NB Obst/ Max Efforts	11-13/16	11-12/15	10-11/14	10-11/13

Ω Size of the Arena (see Art 536 above) - If the arena is **less than 5000 square meters**, the maximum speed for Three and Four Star events shall be **350 meters/min**
 In arenas **less than 2300 square meters** the maximum speed for any level shall be **325/min**

ANNEX 5 – Diagram of Cross Country Obstacles & Faults

DIAGRAM OF CROSS-COUNTRY OBSTACLES & FAULTS

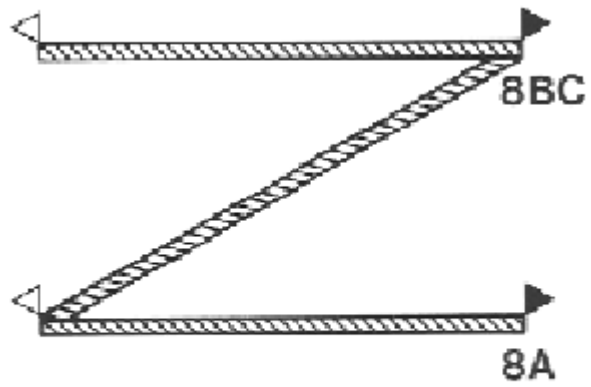

Art. 533.2.1

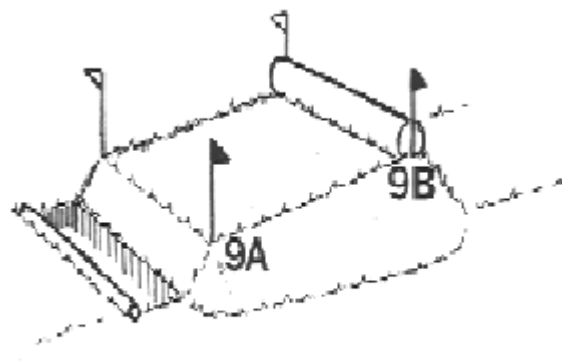

Art. 533.2.1

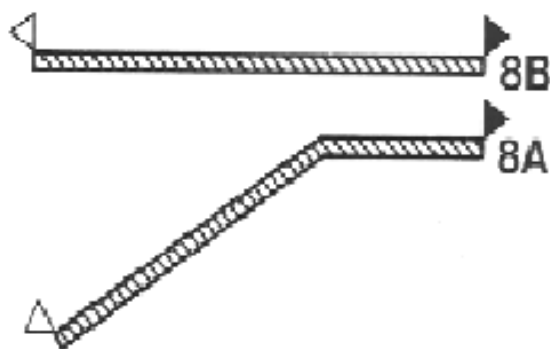

Art. 533.2.1

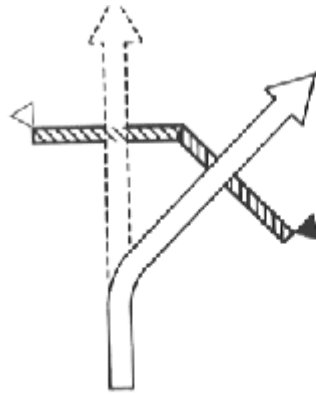

Change of intention by rider

Original intention
 Art. 533.2
 If no refusal - 0 penalty

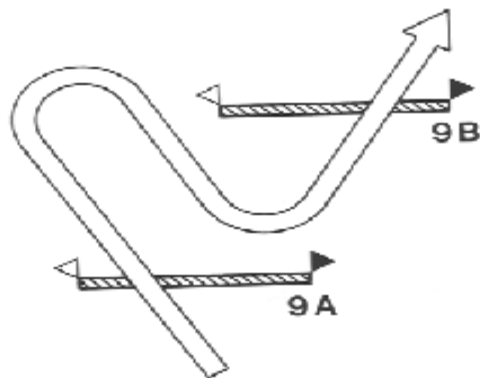

Art. 533.2
 If no refusal and no run-out - 0 penalty

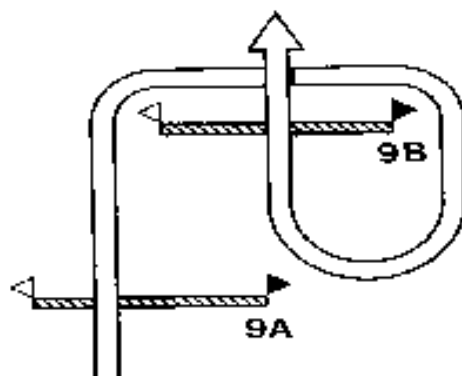

Art 533.3.1
 0 penalty

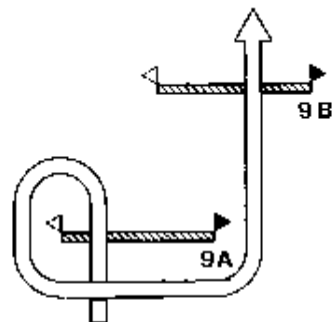
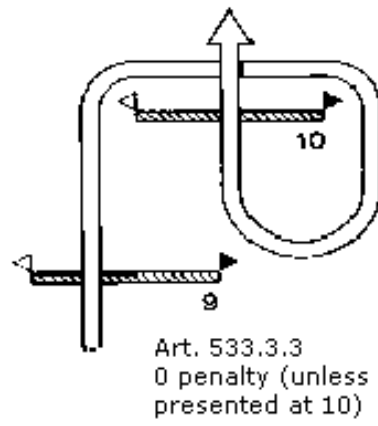
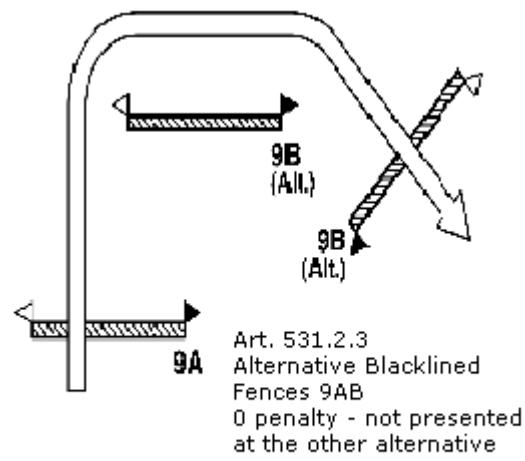

20 penalties - Art. 533.3.1

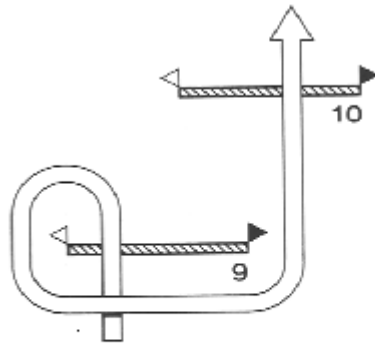

0 penalty - Art. 533.3.3

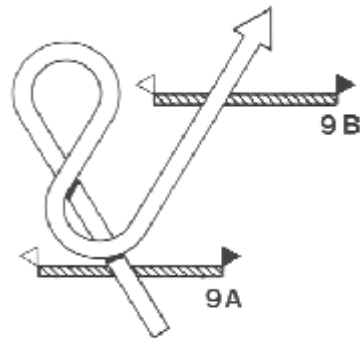

20 penalties - Art. 533.3.1

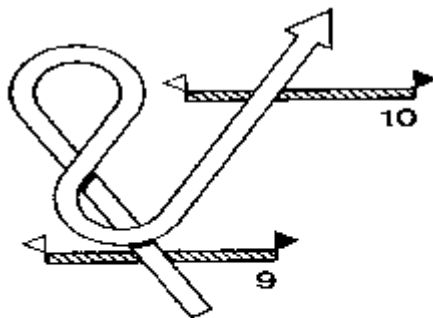

0 penalty - Art. 533.3.3

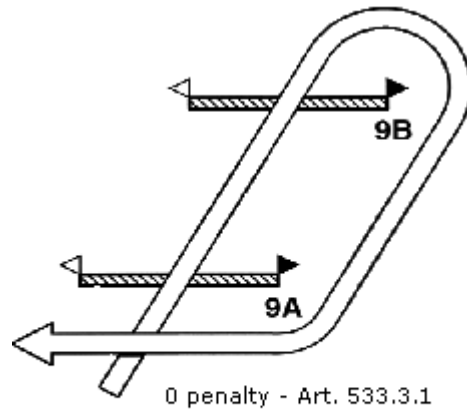

0 penalty - Art. 533.3.1

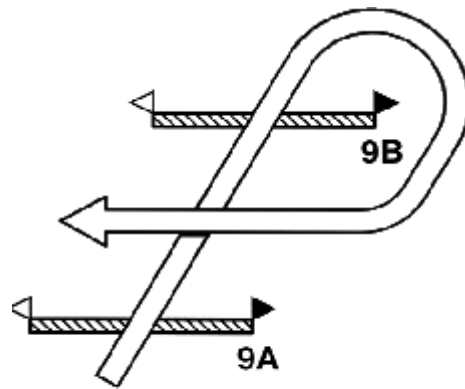

0 penalty - Art. 533.3.1

ANNEX 6

FEI BADGES OF HONOUR

Badges of Honour will be awarded to Athletes who complete the competition at Championships/CCI(O)s Four Star Level (4*), according to the following scale:

- A Gold Badge for completing six Championships/CCI(O)s
- A Silver Badge for completing four Championships/CCI(O)s
- A Bronze Badge for completing two Championships/CCI(O)s.

Eventing at the Olympic Games or at the World Championships is equivalent to two CCI(O)s.

ANNEX 7

Athlete Identity – refer to Art 519.1

RECOMMENDATIONS FOR MEDICAL SERVICES AT FEI COMPETITIONS

Medical attendance at Event: The provision of medical cover must be for the whole duration of the competition and must include the training areas, stables and on-site accommodation. First aid must also be provided for spectators. There should be a physician in the stable area at competitions if feasible. At the least, a physician should have credentials allowing access to the entire facility at all times including the stable area and finish area during competition

Chief Medical Officer: A Chief Medical Officer, suitably experienced and with local knowledge must be appointed well in advance, to act in liaison with the Organising Committee and the emergency services for the adequate provision of medical resources.

A meeting of medical officers or delegates should be held at the cross country venue to familiarize them with the event plan and services available by the host physicians in case of emergency.

A list of phone numbers of medical officers for each team should be obtained at every competition. For teams with no physician, the physiotherapist, or trainer, or lay person designated as a contact in the event of a medical emergency should give a contact phone number to the host physicians.

Text messaging to the medical officers in the event of the need for medical services is a valuable way to communicate. This can be done to a specific physician, or can be a general notice depending on the issue.

Cross Country: At least during the Cross-Country and Jumping Test, full specialist trauma and resuscitation skills, equipment and vehicles must be available on site; the latter should have the capability of rapid deployment to any part of the arena or course in adverse conditions. Radio communication should be made available to alert the emergency services instantly and a telephone line reserved for immediate communication with the designated accident and emergency hospital.

The Cross-Country Test will require several qualified doctors experienced in dealing with trauma, the number depending on the layout of the courses and the accessibility of the site. However, there must be at least one doctor present throughout all the tests.

A Medical Centre should be established on site for the treatment of minor ailments and for the observation and initial treatment of serious injuries or illness. Rapid routes for access and departure must be prepared and safeguarded for the expeditious transfer of the seriously injured to hospital. Depending on the access to the site and the distance to hospital, helicopter evacuation may be required. A suitable area adjacent to the medical centre should be provided. The provision of a suitably equipped helicopter is in any case recommended.

If an athlete falls at a competition, he should not be allowed to continue without a medical assessment, even if the athlete has no obvious injury. Frustrated athletes who fall and then refuse medical attention create an issue for the host medical service providers. Athletes have the right to refuse treatment, but not the right to compete with injuries that may be undetected.

NEW ANNEX 8

ORGANISING REQUIREMENTS FOR EVENTING 4 STAR LEVEL EVENTS

Four star events are believed to be the pinnacle of the sport representing Eventing on the world stage and as such it is felt that there should be some guidelines for potential OCs to ensure that the image of the sport and the presentation of the event are of the highest possible quality.

The FEI will only recognise a few events at this level and this recognition will be subject to some strict criteria.

1. Before being awarded an event of Four Star status the OC must have run, at the venue, a lower level international Eventing competition of at least Three Star level, and demonstrated the ability to stage an event of the highest level.
2. **Application from the host NF** to the FEI to stage a Four Star competition must be accompanied by a proposal including detailed information about the venue (access, facilities, etc) and the suitability of the footing, the OC, the financial viability (including proposed levels of sponsorship income), budget and cash-flow, local accommodation availability, and proposed level of prize money.
3. The OC must have a proven track record of success. A business plan must be presented.
4. **TV Strategy:** Details in regard to the OCs TV strategy as well as expressions of interest in regard to TV coverage.
5. The venue needs to be approved by an FEI appointed Delegate, who will visit the proposed event at the OC's/NF's expense.
6. The NF will be responsible for supporting the application and overseeing the success of the event, and a representative of the NF must be included in the Board of the OC.
7. **Minimum level of prize money:** € 100'000 (CHF 156'000 / \$ 123'000).
8. **Requirement for CCTV:** Mandatory for public, Athletes, owners and the Ground Jury and for safety reasons.
9. **Course Designer:** must be an International Eventing Course Designer and proposed name must be included in the proposal. The Course Designer in question must support the proposal and guarantee that the venue is suitable for the Four Star.
10. **All weather dressage arena:** strong recommendation.
11. **Dates:** dates must fit in to overall Eventing calendar, not clash with any major event and be consistent from year to year in order to allow the other events to position themselves in consequence.
12. Application to be sent to the FEI by July the year preceding the event applied for.
13. The event has to be approved by the FEI Eventing Committee who reserve the right to ask for as much information as is considered necessary. The Eventing Committee also reserves all rights to not accept the 4* denomination request of any organiser.
14. A Review Committee composed of Representatives of the Eventing Committee, FEI Delegate and the FEI Secretary General will assess existing Four star events on a yearly basis. Should any event not fulfil requirements it will be possible to re-evaluate the star level.

ANNEX 9

DIRECTIVES FOR ONE, TWO & TAR CCI/CIC WITH SEVERAL SECTIONS OF THE SAME LEVEL IN REGARD TO GROUND JURIES

1. If an OC wishes to organise several sections of competitions at the same level of difficulty at a one or two star CCI/CIC the whole competition can be treated as a single entity as follows:
2. Where there is more than one section of an event, there shall only be one Ground Jury for the event, consisting of a President and one or two members who will be responsible for all decisions common to the various sections. (President and one member at CICs).
3. Additional Judges will be appointed to assist in the judging of the Dressage, if necessary to make up the horse inspection panels and if required, to help judge the Jumping test. These additional judges may be taken from the FEI lists of official, international or candidate judges or may be national judges. At a CCI there must always be three judges judging each section of dressage; at a CIC there must always be two.
4. At a CCI, at least one member of the Ground Jury must officiate at each Horse Inspection. All horses in any section must be inspected by the same Veterinarian and Ground Jury member at all three inspections.
5. There must be only one Technical Delegate to officiate in all sections of an event organised at the same star level.
6. The Ground Jury must consist of members selected by the OC in accordance with the rules for the relevant star level.
7. The procedure by which Athletes are divided between sections must be specified in the schedule.
8. Prize Money should normally be the same for each section and must be specified in the schedule.
9. Athletes with more than one horse should have their horses split between the sections.

ANNEX 10

CONSULTATION WITH ATHLETES

1. Appointment of Athlete Representative

Prior to the Athletes' first opportunity to inspect the cross-country course every Organising Committee (**OC**) of an international event must appoint an Athlete Representative (**RR**) from among the Athletes taking part in the competition having first obtained that Athlete's consent. This RR has the task of acting as a channel of communication between the Athletes and the officials on any matter directly connected with the event without in any way removing the right of any Athlete to speak to the OC, Technical Delegate (**TD**), Ground Jury (**GJ**), or Course Designer (**CD**). The name of this Athlete must be notified to the Athletes at the briefing if one is held or posted prominently on the event notice board if no briefing takes place.

2. Chairman of Ad Hoc Committee (AHC)

The OC will appoint prior to the start of the competition the Chairman of an Ad Hoc Committee (AHC) – see # 9 below.

3. 1st meeting of Athletes called by the Athlete Representative – 1st HI

At the end of the day on which the First Horse Inspection is held there will be a meeting of all Athletes should they so wish to be called by the RR. The TD and representative of the OC should attend although not the Ground Jury unless specifically requested by the TD, OC or the RR.

4. 2nd meeting of Athletes called by the Athlete Representative after 1st day Dressage

If the event is a "normal" CCI following a 'normal' timetable the RR has the right, if there are any concerns amongst the Athletes, to ask for an Athletes' meeting to take place at the end of the first day of Dressage to discuss major issues concerning the obstacles on the course and/or the distances of the course/phases. This meeting must be attended by the Ground Jury, TD, CD, and a senior representative from the OC. (If there are no issues the RR may advise the TD who will contact the OC and GJ and cancel the meeting).

5. Meeting Minutes

At this meeting any such issues must be recorded in writing (the TD & RR have this responsibility) and the response of the GJ also recorded in writing and signed by the President of the GJ and the RR.

6. Additional Athlete Representative

At this stage the Athletes may appoint a further two people (to join the already appointed RR) as RR's to continue the discussions with the officials and the OC. These additional two people can be anyone the Athletes choose and do not necessarily have to be competing at the competition.

7. Final Athletes Meeting of the Athletes before the Cross Country

A further and final Athletes' meeting, attended as before by all the officials and a representative from the OC, is now required. Ahead of this meeting the written response by the Ground Jury to any written concerns of the Athletes raised the previous evening shall be given to the RR's. At this meeting any final briefing of the Athletes will take place. If the Athletes are still dissatisfied with the decisions of the GJ a vote will be taken. This should be a secret vote and the OC should assist the Athletes in conduct of the meeting. The issue to be voted on is "Do you accept the responses of the Event Officials, or should they be referred to the AHC for final decision?" If a majority of the Athletes actually taking part in the competition (50% plus one) so agree the outstanding issue(s) will be referred immediately to the AHC for a final decision against which there will be no appeal. At this meeting any such issues must be recorded in writing (TD & RR responsibility) and the response of the AHC also recorded in writing and signed by the Chairman of the AHC and the RR.

8. Athletes Briefing

The usual Athletes briefing on routine matters to do with last minute changes due to meteorological conditions, ground etc must still take place on the evening before the cross-country. In case of dispute on such issues, the procedure with the AHC is available for use.

9. Ad-Hoc Committee

The AHC will consist of three people appointed on the first day of the event by the OC in conjunction with the RR – a non-competing current or recent Athlete experienced at the level of the event, a FEI qualified CD or TD, and a third independent person experienced in the sport, e.g. an Organiser. If such people are not available at the event the OC, in consultation with the TD and the President of the GJ, must appoint a committee of similarly experienced people likely to have the confidence of the Athletes and officials alike. Any one of these three people can be appointed as Chairman. The President or a member of the Appeal Jury may be appointed to this committee if suitably qualified.

10. Events with only 1 day Dressage

At a CIC or CCI with only one day of Dressage it will be necessary to modify the above procedure. In these circumstances the above timetable may be compressed and/or certain steps omitted but the most important principles must be retained, i.e.:

- Concerns and responses recorded in writing
- The opportunity for Athletes to vote if dissatisfied
- Final decision by an Ad Hoc, independent Committee, provided a majority of starters so request

Note: It is recommended that the Ad Hoc Committee established above, whether or not it actually meets or has to take a decision, should also act as the committee of investigation reporting to the President of the Ground Jury in the event of a fatal accident to horse or Athlete and as the investigators required by the Ad hoc Investigation team (see FEI Eventing Memorandum/Guidelines). This recommendation is intended to avoid duplication of effort and of officials.

*The article will not apply for Championships, Team events, Young Athletes **or** Juniors events
The above will not apply for Championships or team events (RR replaced by Chef d'Equipe)
or for Young Athletes, Junior of Pony events.*

ANNEX 11

Young Rider/Junior Championships - SCHEDULE Information

The Organising Committee should prepare a schedule, which should include the following information:

1. Type of event
2. Description of the competitions
3. Prizes, trophies to be awarded
4. Height, spread of obstacles, distances, times, speeds and jumping efforts for both the Cross-Country and Jumping Tests together with Dressage Test details
5. Type of obstacles
6. List of Officials (Judges, Technical Delegates, Course Designers, Veterinarians, Stewards) etc
7. Programme of competitions
8. Programme of social events
9. Lodging of Chefs d'Equipe and Athletes which may be in hotel or with private families
10. Arrangements for parents, including a list of hotels where parents can book direct and not through the Organising Committee – list of prices
11. Accommodation of grooms – location in vicinity of stables
12. Stabling of horses – details of cost
13. Fodder available for horses – details of cost
14. Local transportation arrangements
15. Arrival and departure dates, outside which no expenses will be paid
16. Other useful information such as passport and visa requirements, climate, type of clothes needed, etc.
17. Several copies of this schedule should be sent to all NFs at least eight weeks before the start of the event and championship.

ANNEX 12

Rules for Eventing Pony Riders

Pony Riders' competitions are an important element in the development of equestrian sport around the world. The objective of this Annex is to define a framework within which Pony Riders can practise the sport of Eventing in a safe and appropriate way. Thus the FEI Rules of Eventing apply with the modifications and clarifications defined in this Annex.

ADMINISTRATIVE RULES

Article P1 - DEFINITION OF PONY RIDER AND PONY, AND PARTICIPATION

Age of Pony Rider

A rider may compete as a Pony competitor from the beginning of the calendar year in which he reaches the age of 12 until the end of the year in which he reaches the age of 16.

Participation

A Pony competitor may compete in competitions for Juniors and/or Young Riders if appropriately qualified without losing his status as a Pony competitor. He may likewise take part in competitions and Championships of more than one category, but only in one age category and in one discipline of such Championships in any one calendar year.

Definition of a Pony

A pony is a small horse whose height at the withers, having been measured on a smooth level surface, does not exceed 148cm without shoes or 149cm with shoes. Nevertheless, to allow for the fact that FEI pony measurement takes place under competition conditions ponies measured at competition must not exceed 150cm without shoes or 151cm with shoes in order to be permitted to compete.

Age of Pony

In all International Events and Championships, Ponies must be at least six years old.

Article P2 - INTERNATIONAL PONY EVENTS AND QUALIFICATION

Pony events

Events limited to Pony competitors are designated with a 'P' and are of the 1* and 2* level:

- CCIP1* Introductory level
- CCIP2* Level of the European Championship (for competitors and ponies with more experience)

Qualifications

Pony riders and ponies must be certified by their national federation as qualified to compete at the required level.

Article P3 - PRIZES FOR PONY COMPETITORS

- 1 Prize money is not allowed at Pony Events.
- 2 In all Events, one rosette and a prize in kind or souvenir must be awarded for each commenced four competitors with a minimum of five prizes. It is recommended that stable plaques should be awarded to the first four individuals.
- 3 Organising Committees may provide additional special awards/prizes of a sporting nature at their discretion.

Article P4 - PONY MEASUREMENT

- 1 Annex XVIII of the Veterinary Regulations and the General Regulations (Art 139) of the FEI apply.
- 2 All ponies competing at the CH-EU-P will be measured on site before starting the competition. Random measuring at various CIP may also take place.
- 3 Where FEI Pony Measurement is to be carried out before the Horse Inspection, the period of an Event shall commence with the first Pony Measurement. Such provision shall prevail over the General Regulations.

TECHNICAL RULES

Article P5 - DRESS

Protective Headgear

Whenever mounted, protective headgear secured by a 3-point retention harness is compulsory for all Pony competitors. As a safety measure, long hair must be tucked under the headgear or retained in a hairnet.

Spurs

For Pony competitors, the shank must end in a smoothly rounded ball. Rowels are not permitted. Any mark on the pony resulting from inappropriate use of the spurs may lead to sanctions.

Dressage Test

Dark coat or club uniform coat. White or fawn breeches or jodhpurs, white shirt with white or light-coloured tie or hunting stock. Neither top hat nor bowler is allowed. Gloves must be worn. Boots as defined in Article 521 4. Spurs are optional.

Cross-country Test

Jodhpurs are allowed with appropriate footwear.

Jumping Test

Dark coat or club uniform coat. White or fawn breeches or jodhpurs, white shirt with white or light-coloured tie or hunting stock. Neither top hat nor bowler is allowed. Gloves must be worn. Boots as defined in Article 521.4. Spurs are optional.

Article P6 - SADDLERY

Exercise Areas – Article 522.1 applies except that hackamore, curb and double bridle are not allowed.

Dressage Test – Article 522.2 applies except that curb and double bridle are not allowed (only snaffle bits).

Cross-country and Jumping Tests - Article 522.3 applies except that curb, double bridle, hackamores and bit less bridle are not allowed.

Article P7 - DRESSAGE TEST

Refer to Annex 2 modified.

Article P8 - CROSS-COUNTRY TEST

The same rules and regulations apply for one star as for two star Pony events. However, the course should be designed keeping the purpose of the one star event in mind, which it is to introduce ponies and riders to their first one star international competition. In principle, obstacles must be more inviting than the obstacles for two star events, with an acceptable number of alternatives.

Distances and Speeds

PONY CROSS COUNTRY	Two Star (2*)	One Star (1*)	
Heights			
Fixed	1.05 m	1.05 m	
Brush	1.25 m	1.25 m	
Max Spreads			
Highest Point	1.25 m	1.25 m	
Base	2.10 m	2.10 m	
Without height	2.80 m	2.80 m	
Max Drop	1.45 m	1.45 m	
PONY CROSS-COUNTRY	Pony Championships	Two Star (2*)	One Star (1*)
Speed	520 mpm	450 - 520 mpm	450 -520 mpm
Time	7 -8 min	6-8 min	6-8 min
Distance	3640-4160m	2700 - 4160m	2700 - 4160m
Jump. Efforts	Max 30	Max 30	Max 30

Types of Obstacles

1. Bull finches are not allowed.
2. Bounce fences (combination of upright obstacles with no stride) are allowed but must not be into water and must be of an appropriate distance, and degree of difficulty, for ponies and pony riders.
3. The drop on the landing side of an obstacle, or of those obstacles that are jumped as a ski jump, may never exceed 1.45m. The number of such obstacles is limited to two. The number of drop fences less than 1.45m is left to the discretion of the Technical Delegate.

Article P9 - JUMPING TEST

The same rules apply for both one and two star events.

The course should be 400 to 500m with maximum 11 obstacles and 13 jumping efforts, obstacles not exceeding 1.10m in height and maximum 1.35m in spread. There must be at least one double. Speed: 350m per minute.

JUMPING CCIP 1*/2*	Pony One Star (1*)	Pony One Star (2*)
OBSTACLES		
Heights:	1.10 m	1.10m
Overall Spreads		
Highest point	1.25m	1.25m

Base or Triple bar	1.80m	1.80m
Distance	350-450 m	400-500m
Speed	350m/min	350m/min
NB Obst/ Max Efforts	10-11 / 13	10-11 / 14

Article P10 - OFFICIALS

Duties of Technical Delegates

In addition to the above responsibilities, the Technical Delegate at Championships for Ponies and at International Events shall have the responsibility and the authority to check that all facilities are adequate, that the behaviour of participants is correct and that social and educational functions are conducted with the utmost care, always bearing in mind the welfare of the participants and the development of the best spirit of sportsmanship and fair play.

Officials

Officials are to be appointed according to the Table below. Organising Committees are strongly advised to include officials who have experience of Pony events.

	CH-EU-P	CCIOP2*	CCIP2*	CCIP1*
Ground Jury	3 members	3 members	2 or 3 members	2 or 3 members
	Appointed by FEI, from the FEI	All must be chosen from FEI	All must be chosen from FEI	1 GJ member from the FEI
	"O" or "I" lists At least 2 Members of the Ground Jury must be foreign. President, at least, must have experience judging Pony events	"O" or "I" lists At least 2 Members of the Ground Jury must be foreign. At least 1 GJ member must have experience judging Pony events	FEI lists One Foreign Member of the Ground Jury or a Foreign TD is compulsory	lists Can be National Judges if the TD is chosen from the FEI lists
Appeal Committee	1 member with experience of Pony events		N/A	
Technical Delegate	Appointed by the FEI from "I" list	Must be chosen from the FEI "I" list of Technical Delegates		One member of the GJ or the TD must be chosen from FEI lists. The TD may be National if a member of the GJ or the CD is on the FEI lists

Course Designer	Must be chosen from the FEI "I" list of CDs	May be from the FEI lists or be a National CD as long as a member of the GJ or the TD is on the FEI lists
-----------------	---	---

Article P11 - CONTINENTAL CHAMPIONSHIPS

The Continental Championship will be organised each year and, as far as possible, during the long school holidays.

Jumping, Dressage and Eventing Championships should be, as far as possible, organised within the same Event to save travel costs. Organising should alternate among the nations of the Continent, giving the Pony competitors the possibility to visit as many foreign countries as possible.

Outside Europe, a Continental Championship may be held with any number of regional teams from at least two countries including the host nation. The NF's of the nations concerned will determine the basis of the regional teams.

NF's from outside the Continent may be invited if authorised by the Secretary General of the FEI, but no rider may take part in two Championships in the same discipline within one calendar year. Riders from outside the Continent are eligible for prizes but not for medals or title classification.

Teams

Each NF may enter one team of not more than six competitors and six ponies from which four may start in the Team Championship. Teams of three are allowed. An NF which cannot send a Team may enter one or two individual competitors with one pony each.

For each team, the Organising Committee must extend its invitation to a Chef d'Equipe and a Veterinarian who will be given the same privileges as the competitors.

Grooms

NFs are entitled to send one groom for each two ponies with a maximum of three grooms per team.

Competitions

Championships will be run as CCIP2* competitions.

Officials for Championships

The President and members of the Ground Jury, the TD and the Foreign Veterinary Delegate will be appointed by the FEI who will approve all other appointments. Other officials will be appointed by the Organising Committee/NF based on the criteria set out in the Table below.

The Organising Committees are strongly advised to include officials who have experience of Pony events.

Expenses

NFs are responsible for the travelling expenses of their Chefs d'Equipe, competitors, grooms and ponies to and from the location of these Championships.

Reasonable entry fees may be charged and must be approved by the FEI.

The Organising Committee must make appropriate provision for on site stabling and for the grooms to stay in the immediate vicinity of the stables.

If accommodation is not offered free to the competitors, then suitable accommodation should be defined and listed in the Schedule.

Prizes and Souvenirs

At Championships only prizes in kind can be awarded; prize-money is not allowed. The following minimum number of awards must be presented:

In the Team Championship, FEI medals will be distributed. In addition, prizes in kind, plaques and rosettes for each of the competitors in the teams taking the first four places.

In the Individual Championship, FEI medals will be distributed. In addition prizes in kind, plaques and rosettes at a rate of one prize for each commenced four competitors with a minimum of five prizes. Organising Committees may provide additional special awards/prizes of a sporting nature at their discretion.

All Chefs d'Equipe and competitors shall be presented with a souvenir or a plaque by the Organising Committee. At Championships, the prize giving ceremonies must be given particular importance and held in the arena with the prize winners properly dressed and mounted on their ponies.